

Standard Series FP1272 12V7.2Ah

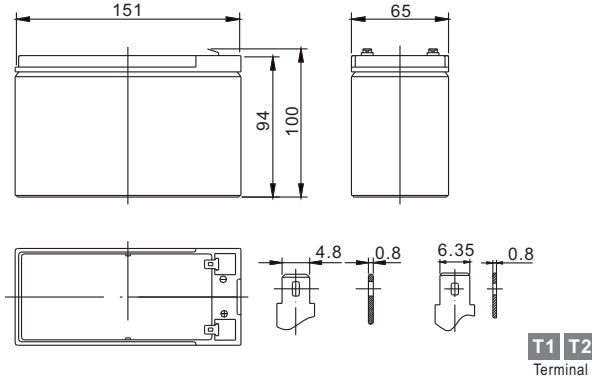

Dimension(mm)



Specification

Nominal Voltage		12 V
Capacity(20HR, 25°C)		7.2Ah
Dimension	Length	151mm (5.94inch)
	Width	65mm (2.56inch)
	Height	94mm (3.70inch)
	Total Height(T1/T2)	100mm (3.94inch)
Approx. Weight		2.30kg (5.06lbs)

Characteristics

Capacity 20°C (68°F) To 1.70V/Cell	20 hour rate	7.2Ah
	10 hour rate	7Ah
	5 hour rate	5.65Ah
	1 hour rate	4.55Ah
	15 min rate	3.35Ah
Internal resistance(Fully charged, 25°C)		Approx. 25m Ω
Capacity affected by temperature (20HR)	40°C	102%
	25°C	100%
	0°C	85%
	-15°C	65%
Self-discharge (25°C)	3 month	Remaining Capacity: 91%
	6 month	Remaining Capacity: 82%
	12 month	Remaining Capacity: 65%
Nominal operating temperature		25°C ±3°C(77°F ±5°F)
Operating temperature range		-15°C~50°C(5°F~122°F)
Float charging voltage(25°C)		13.60 to 13.80V
Cyclic charging voltage(25°C)		14.50 to 14.90V
Maximum charging current		2.1A
Terminal material		Copper
Maximum discharge current		105A(5 Sec.)

The Relationship for Open Circuit Voltage and Residual Capacity (25°C)

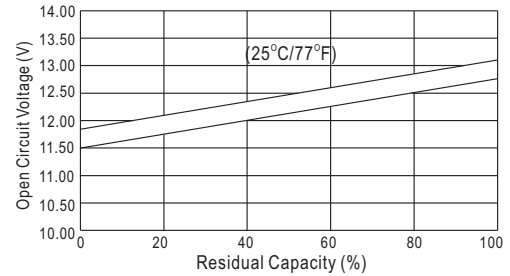

Charging Characteristics(25°C)

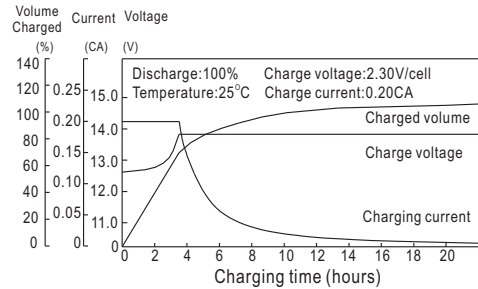

Cycle Life(25°C)

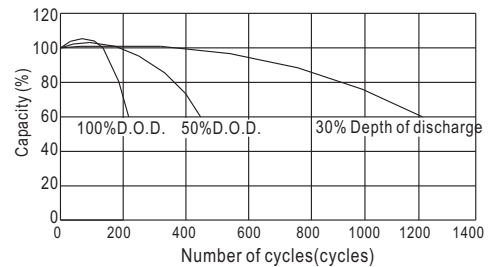

Constant Current Discharge Characteristics (A, 25°C)

F.V/TIME	5min	10min	15min	30min	60min	3h	5h	10h	20h
9.60V	27.4	18.0	14.0	8.20	4.70	1.83	1.24	0.71	0.37
10.2V	26.0	17.1	13.4	7.86	4.55	1.80	1.22	0.70	0.36
10.8V	24.4	16.1	12.7	7.46	4.35	1.76	1.20	0.68	0.36

Constant Power Discharge Characteristics (Watt, 25°C)

5min	10min	15min	30min	60min	3h	5h	10h	20h
305	203	160	92.0	54.4	21.7	14.8	8.52	4.43
290	191	153	88.2	52.7	21.4	14.6	8.40	4.37
273	180	145	83.8	50.4	21.0	14.3	8.17	4.32