

Standard Series FP1223 12V2.3Ah

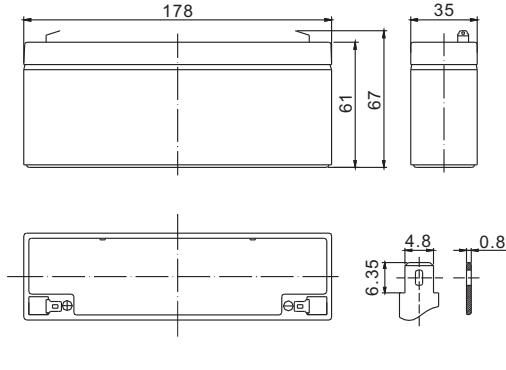

Dimension(mm)



Specification

Nominal Voltage		12 V
Capacity(20HR, 25°C)		2.3 Ah
Dimension	Length	178mm (7.01inch)
	Width	35mm (1.38inch)
	Height	61mm (2.40inch)
	Total Height	67mm (2.64inch)
Approx. Weight		0.97kg (2.13lbs)

Characteristics

Capacity 20°C (68°F) To 1.70V/Cell	20 hour rate	2.3Ah
	10 hour rate	2.2Ah
	5 hour rate	1.95Ah
	1 hour rate	1.48Ah
	15 min rate	1.08Ah
Internal resistance(Fully charged, 25°C)		Approx. 60m Ω
Capacity affected by temperature (20HR)	40°C	102%
	25°C	100%
	0°C	85%
	-15°C	65%
Self-discharge (25°C)	3 month	Remaining Capacity: 91%
	6 month	Remaining Capacity: 82%
	12 month	Remaining Capacity: 65%
Nominal operating temperature		25°C ±3°C(77°F ±5°F)
Operating temperature range		-15°C~50°C(5°F~122°F)
Float charging voltage(25°C)		13.60 to 13.80V
Cyclic charging voltage(25°C)		14.50 to 14.90V
Maximum charging current		0.69A
Terminal material		Copper
Maximum discharge current		34.5A(5 Sec.)

The Relationship for Open Circuit Voltage and Residual Capacity (25°C)

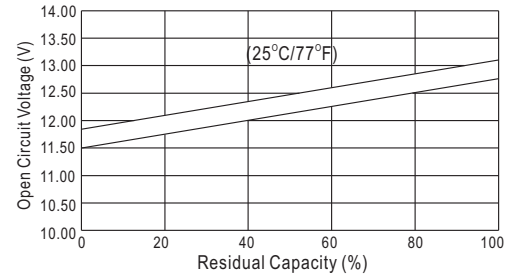

Charging Characteristics(25°C)

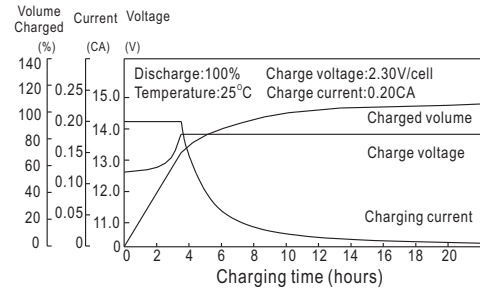

Cycle Life(25°C)

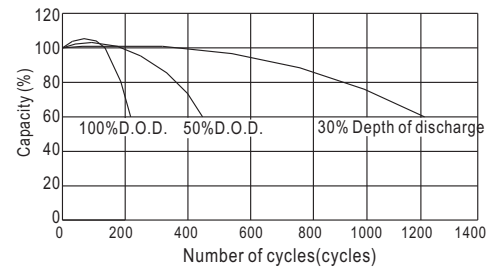

Constant Current Discharge Characteristics (A, 25°C)

F.V/TIME	5min	10min	15min	30min	60min	3h	5h	10h	20h
9.60V	9.20	5.80	4.50	2.60	1.54	0.59	0.40	0.22	0.11
10.2V	8.74	5.51	4.32	2.50	1.48	0.58	0.39	0.22	0.11
10.8V	8.22	5.18	4.10	2.37	1.40	0.57	0.38	0.22	0.11

Constant Power Discharge Characteristics (Watt, 25°C)

5min	10min	15min	30min	60min	3h	5h	10h	20h
103	65.4	51.3	29.8	17.8	6.99	4.73	2.67	1.34
97.5	62.2	49.2	28.6	17.1	6.89	4.66	2.64	1.33
91.7	58.4	46.8	27.2	16.3	6.75	4.56	2.66	1.32